

How to Achieve a Zero Impact Emissions Vehicle with Heavy Duty Diesel Trucks to solve the Environmental Issues for the future beyond EURO 7

ECT 2024 Conference
October 22nd 2024

Dr. Georg Hühwohl (MD Albonair GmbH)



1 Vision for future Emission Regulation

2 How to achieve Zero Impact Vehicles

3 Real Driving Emissions in Cities

4 Conclusions

History of Vehicle Emission Regulation

- regulation of emissions began in 1970 with the EPA's "Clean Air Act" in the USA
- emissions were reduced by the respective possibilities of the "state of the art" technology
→ Scope: air quality improvement, especially in cities
- European emission regulation for heavy duty was focused on particulates and NOx starting in 1991 (EU I) and is now targeting EU 7 in 2030
→ 40 years of improvement
- EURO VI: introduction of RDE emissions

Development of European Heavy-duty Legislated Emissions Limits

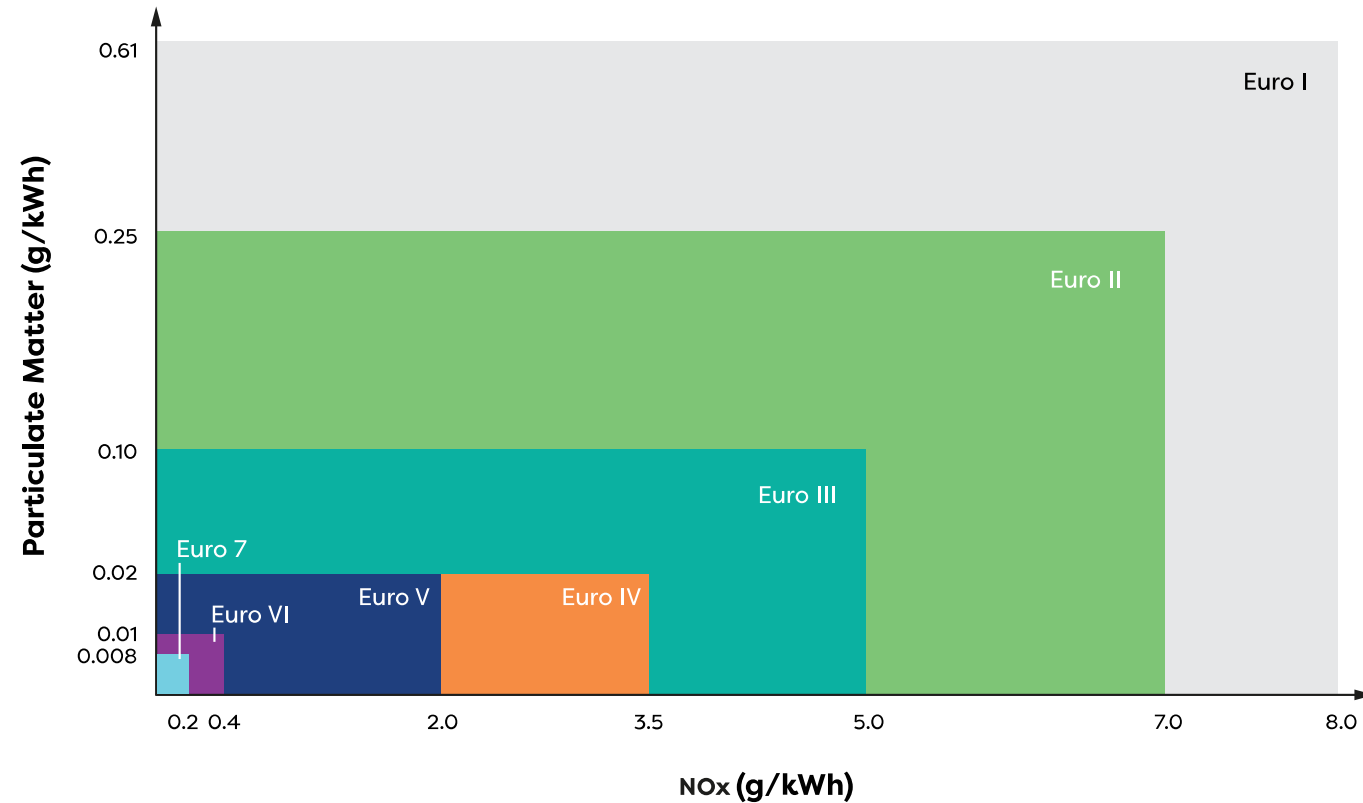

Source: www.aecc.eu/legislation/heavy-duty-vehicles/

Future Emission Legislation will focus on NO_x and CO₂

Main Challenge for tailpipe emission: NO_x in RDE with 7 % power threshold, i.e. almost total city cycle is valid

RDE emission: new EUR 7 vs. EU VI

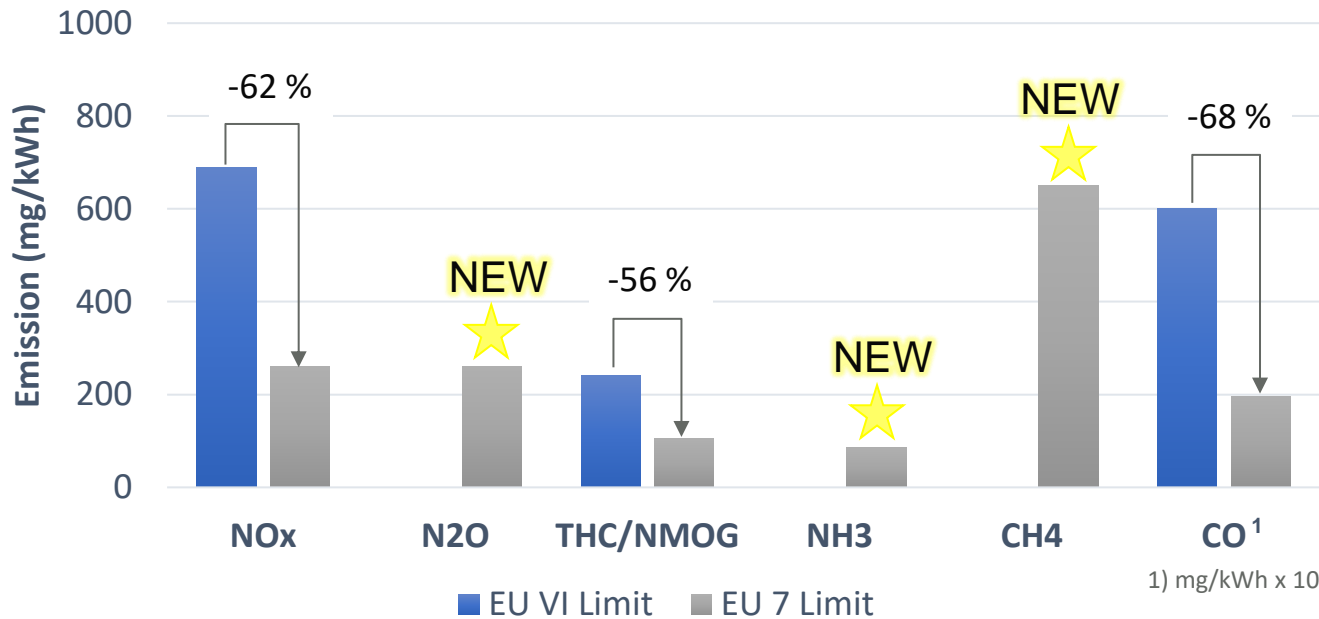

CO₂ fleet regulation

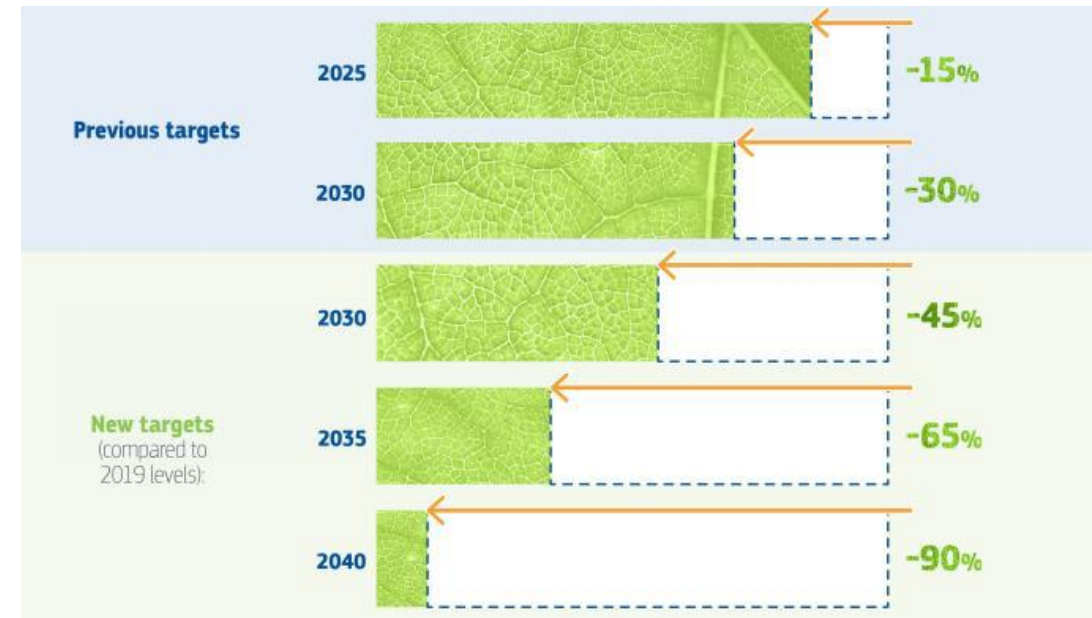

Detection limit of valid particle reduced from PN₂₃ to PN₁₀

Scope of Zero Impact Vehicle Emission Regulation Proposal

A new approach was proposed by the Universities of Graz and Aachen

- Emission regulations should be focussed to avoid an impact by vehicle emissions on the air quality in specific operation profiles
- **ZIE = “Zero Impact Emissions”** is achieved when the impact of the vehicle fleet does not worsen air quality by more than 3 %
- **ZIV = “Zero Impact Vehicle”** is a vehicle whose emissions are so low that they do not have a measurable negative impact on the environment or human health

Study on Zero-impact Vehicle Emissions (ZIE/ZIV)

FVV is an association of the Automotive Industry for basic research.

Members are (European) car and truck manufacturers (VW, Daimler, IVECO, Toyota, Honda ..) and suppliers (BOSCH, Schaeffler, AVL, FEV and also Albonair). In total FVV has 220 members.



To prepare EURO 7 emission regulation FVV started two research projects between 2020 and 2023 to analyze the impact of vehicle emissions on the air quality.

Study was headed by Bosch and VW.

Key Take away:

“Even a complete ZIV emission level fleet, passing a critical inner-city point, would not have a negative impact on air quality.”

ZIV level for HDV was evaluated to be 28,1 mg/kWh for inner city operation, without cold start.



1 Vision for future Emission Regulation

2 **How to achieve Zero Impact Vehicles**

3 Real Driving Emissions in Cities

4 Conclusions

Vision of Clean Diesel Trucks: ZIE Emissions with CO₂ neutral fuels

- Zero Impact Emission is possible using innovative exhaust aftertreatment with external heating
 - Burners
 - Electrically Heated Catalysts
 - CatVap[®]
- Zero or close to Zero CO₂ is possible by using biofuels and e-fuels
- 50 % of the California trucks are operated with biofuels
- e-fuels will be available in the next years

Temperature is the key to achieve ZIE

FEV Demonstrator Vehicle for “EURO 7 Commission Proposal”

FEV's EURO 7 ACTROS DEMONSTRATOR



MEASURED FEV's EURO 7 SYSTEM FOR HDVs

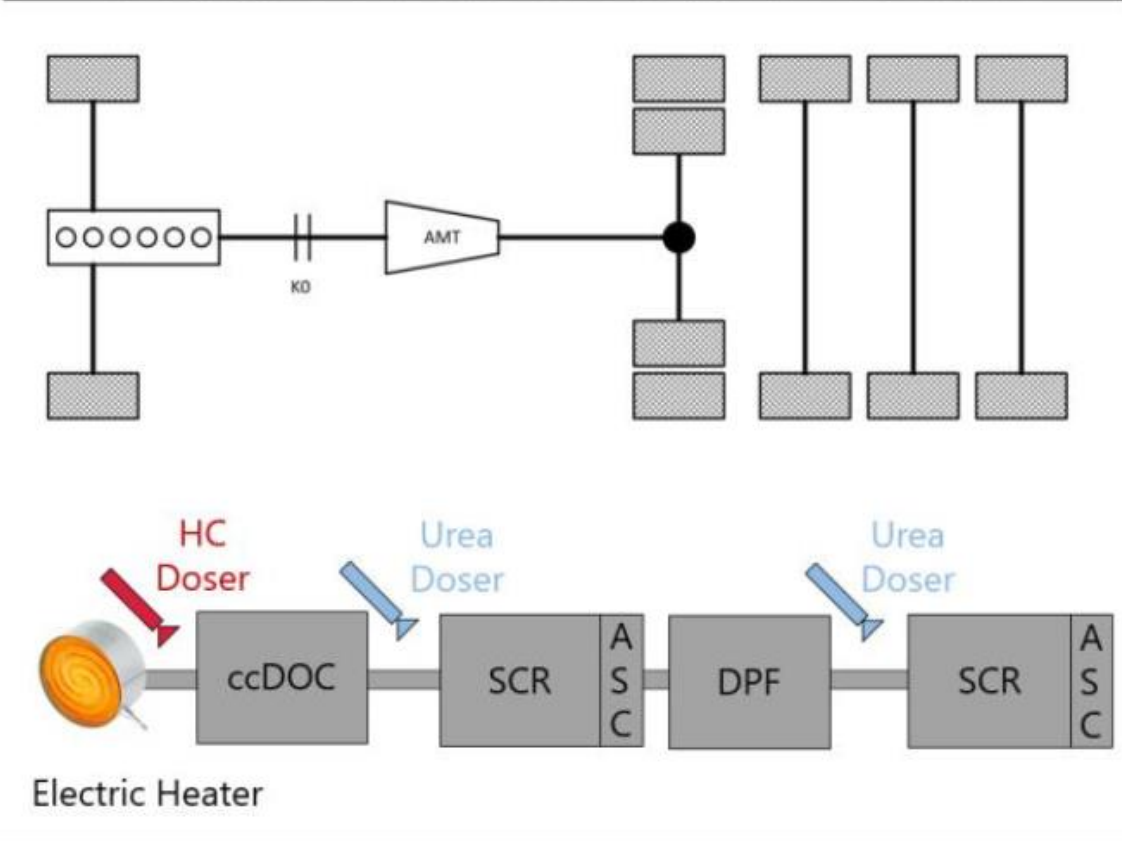

Figure 70: FEV Actros Euro 7 demonstrator vehicle.

Temperature is the key to achieve ZIE

Albonair Demonstrator Vehicle for “EURO 7 Commission Proposal”



- type: commercial vehicle
- gross weight: 7,5 t
- engine: 4 Cylinder, Medium Duty Diesel engine
 - displacement: 5,2 l
 - power: 140 kW
 - torque: 550 Nm

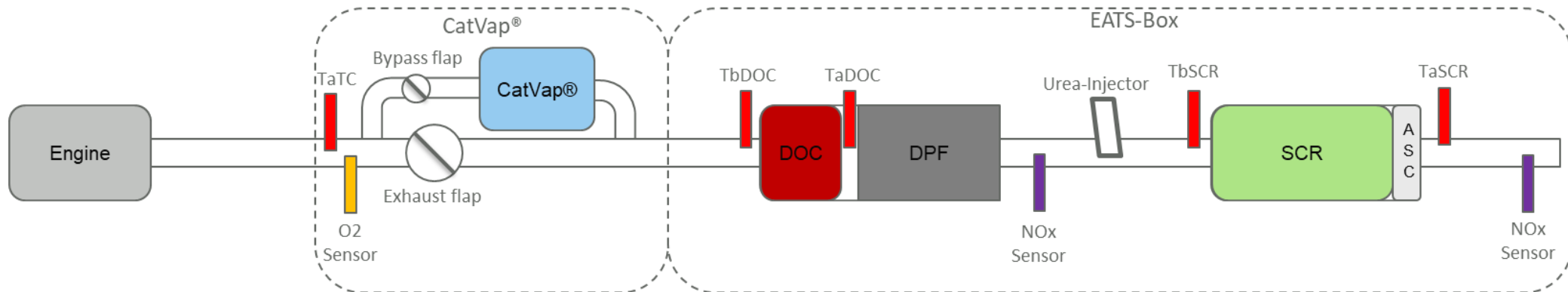

CatVap[®]: flexible heating and heat retention system

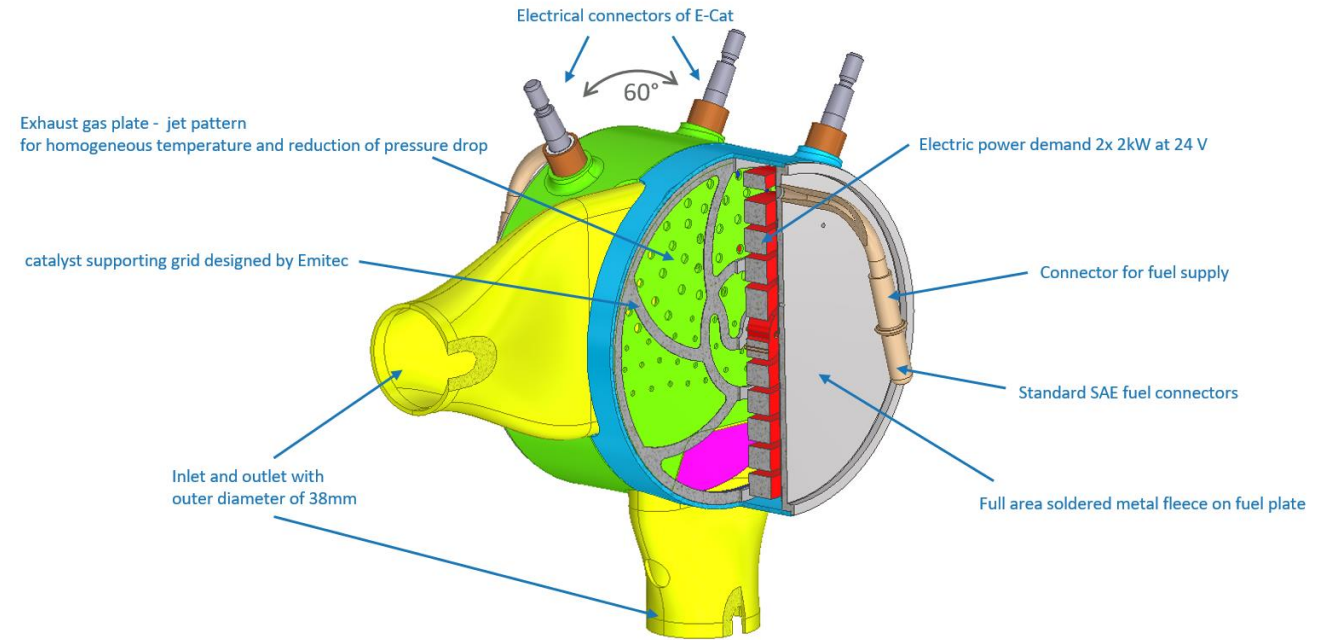
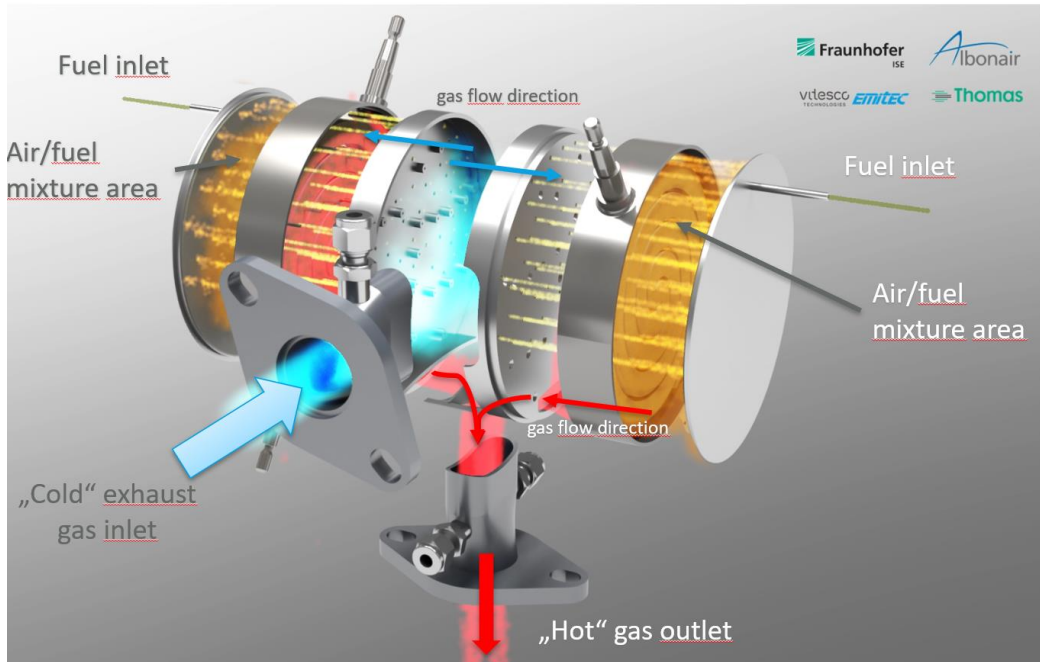

SYSTEM CHARACTERISTICS

- CatVap is a catalytic heating system using already existing components
- Efficient and flexible aftertreatment thermal-management
- Powered with fuel only, after short electrical system start
- No electricity consumption during further operation
- Keeps the exhaust temperature at target temperature independent of engine operation
- Continuous DOC / SCR temperature stabilization in “Heat retention mode”
- Enables active DPF regeneration (replacing HC doser) with high efficiency
- No engine thermal-management required

CatVap[®] system technology – Description & main functions

System description

The fuel processing technology CatVap[®] is a heating measure for Exhaust Aftertreatment systems.

The heat will be provided thermally by adding extra fuel with regulated dosing pumps depending on the actual power requirement into the CatVap[®] system.

- **Heating Mode**

The CatVap[®] system provides the required thermal energy to heat up the DOC in the EATS from cold conditions within the given timeframe.

- **DOC Mode (Diesel dosing function)**

The CatVap[®] system has the capability to provide mainly reactive reductants such as H₂, CO and short chained alkenes to the exhaust flow in order to react on the DOC (diesel oxidation catalyst) of the vehicle EATS whereby reduction of light-off temperature will be achieved.

- **Heat Retention Mode**

The CatVap[®] system is capable to keep the EATS warm and to protect the system from cooling down in (temporary) low load operation areas in order to keep AdBlue-dosing release under all circumstances.

- **DPF Regeneration Mode**

The CatVap[®] system provides the required heat flow to regenerate the DPF (Diesel Particulate Filter) within a given time.

CatVap[®] - Technical Details

- **Power, max. heat up mode:** up to 20 kW
- **Power, max. DOC mode:** up to 100 kW
- **Power min. (heat retention):** 2 kW
(deactivated when engine exhaust temperature is high enough)
- **Max. electrical power of electrical preheating:** 4 kW (12V, 24 V or 48 V possible)
- **Maximum amperage of CatVap[®] during start period:** 180 A at 24 V
- **Maximum operating duration of electrical preheating:** < 150 s within one start period in cold condition for medium duty engine (depending on boundary conditions during start)
- **Mass Flow through CatVap[®]:** up to 150 kg/h can be heated up
- **Pressure drop over complete System (for MD w/ 3" flap: exhaust mass flow of 1.000 kg/h at 500 °C):** ca. 40 - 50 mbar
(for HD w/ 4" flap: exhaust mass flow of 2.000 kg/h at 500 °C): ca. 40 - 50 mbar

-
- 1 Vision for future Emission Regulation
 - 2 How to achieve Zero Impact Vehicles
 - 3 Real Driving Emissions in Cities**
 - 4 Conclusions
-

Exhaust Temperature in inner City Operation: too low for high SCR efficiency

India garbage truck cycle

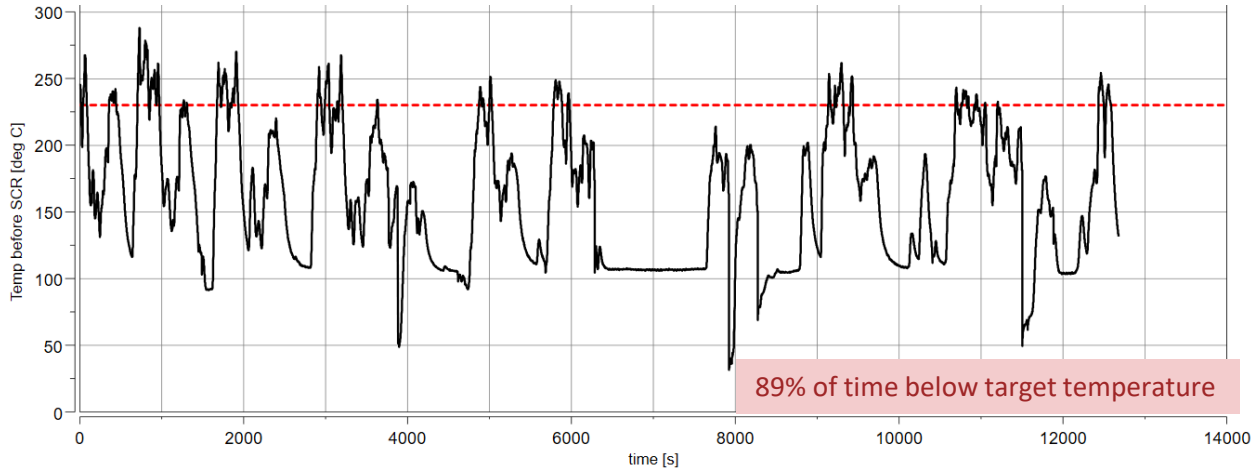

MD truck city cycle (Germany)

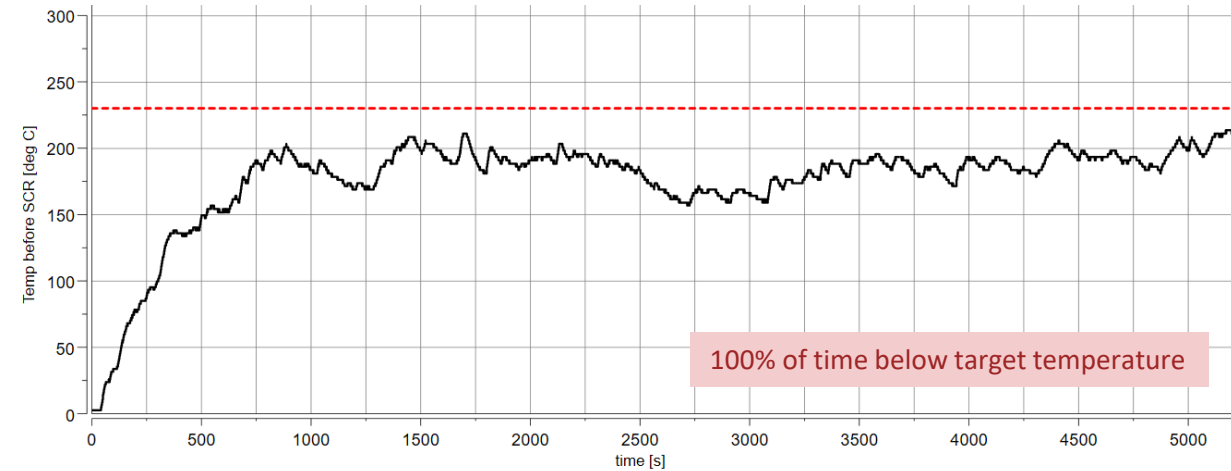

India city bus cycle

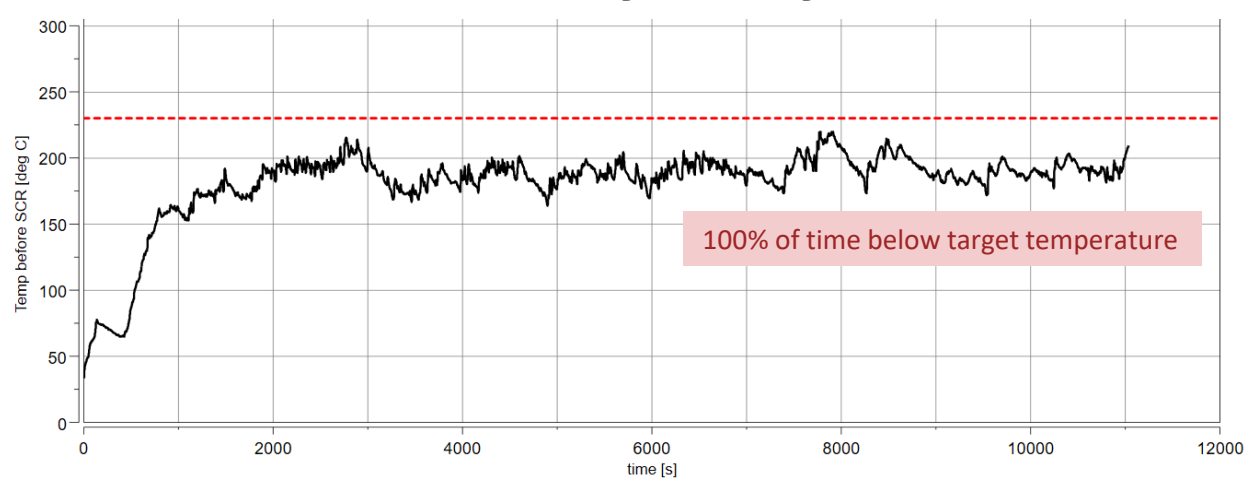

Summary

- Target temperature for sufficient SCT effectivity: 230 °C
- Inner City Operations: exh. temperature drops most of the time below 230 °C
- NOx Reduction Efficiency of the SCR Catalyst drops causing NOx peaks
- Measures to keep the exhaust temperature above 230°C are necessary to achieve ZIE

Most commercial vehicles will meet EU VI emission limits by 2030

Retrofitting municipal vehicles can cut emissions in urban traffic by over 90 %

Denitrification catalysts require a temperature of at least 220 °C to reduce almost 100 % NOx

Even EU VI CVs are not reaching the lower SCR limit temperatures in urban operations → NOx breakthroughs

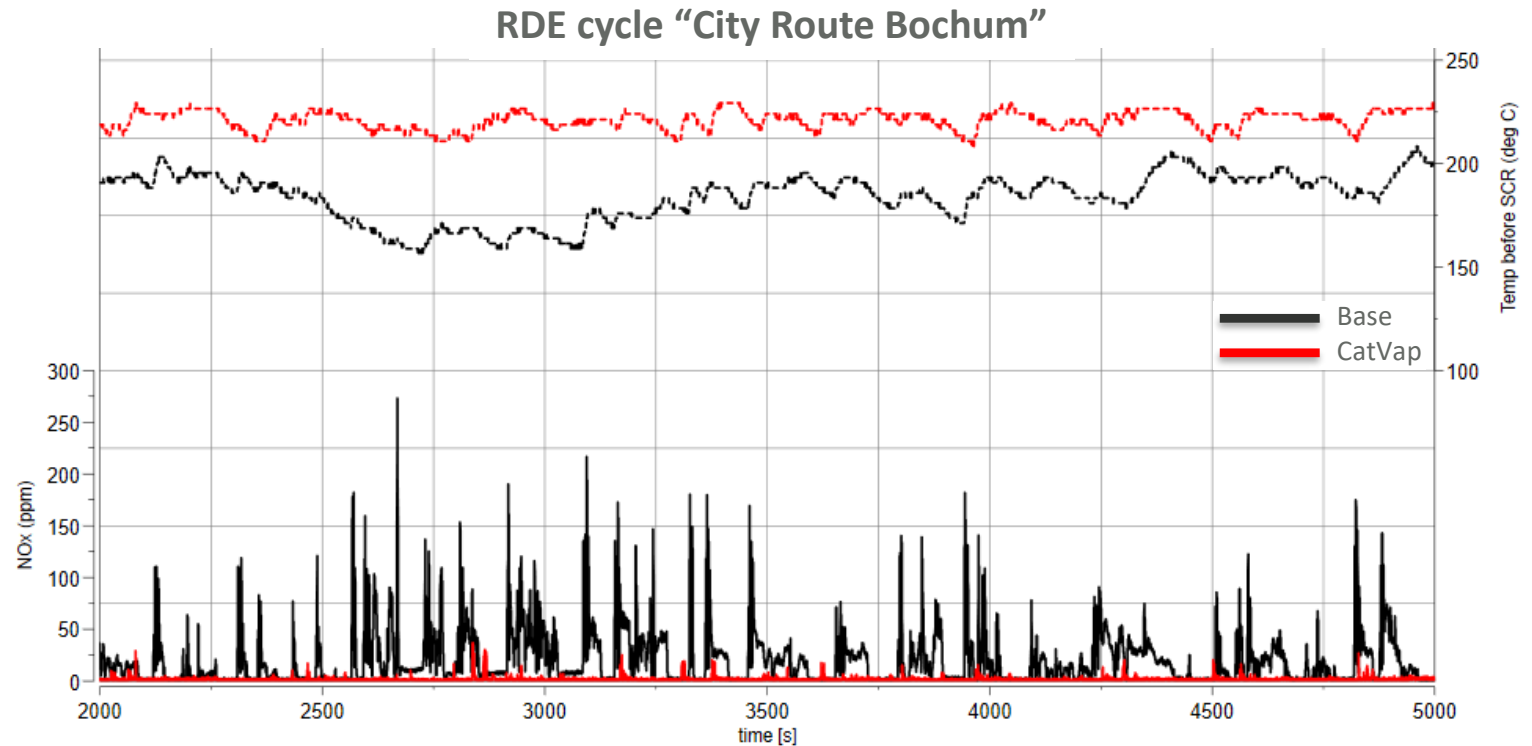
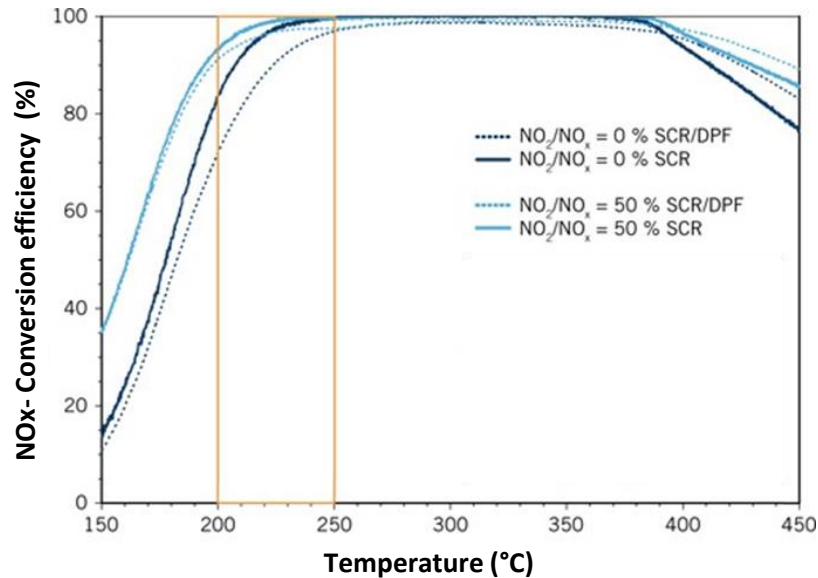

The catalytic heater “CatVap®” developed by Albonair and Fraunhofer ISE reliably keeps the exhaust gas temperature above the required conversion temperature.

RDE-Performance – NOx emission during city cycle

RDE cycle “City Route Bochum”

- Duration: 33 min
- Mileage: 15 km
- Average speed: 27 km/h

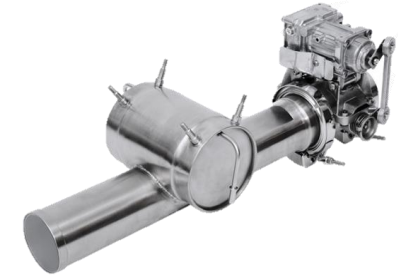

Under worst case conditions

- ➔ 1°C ambient temperature
- ➔ unloaded truck

an Albonair demonstrator (EURO VI d) equipped with a CatVap[®] system achieved 35,4 mg/km NOx.

✓ **This is close to the ZIV target.**

Open question:

Can we meet the ZIV emission targets by retrofitting EU VI city buses and garbage trucks?

CatVap DeNOx Potential - RDE City Cycle “City Route Bochum”

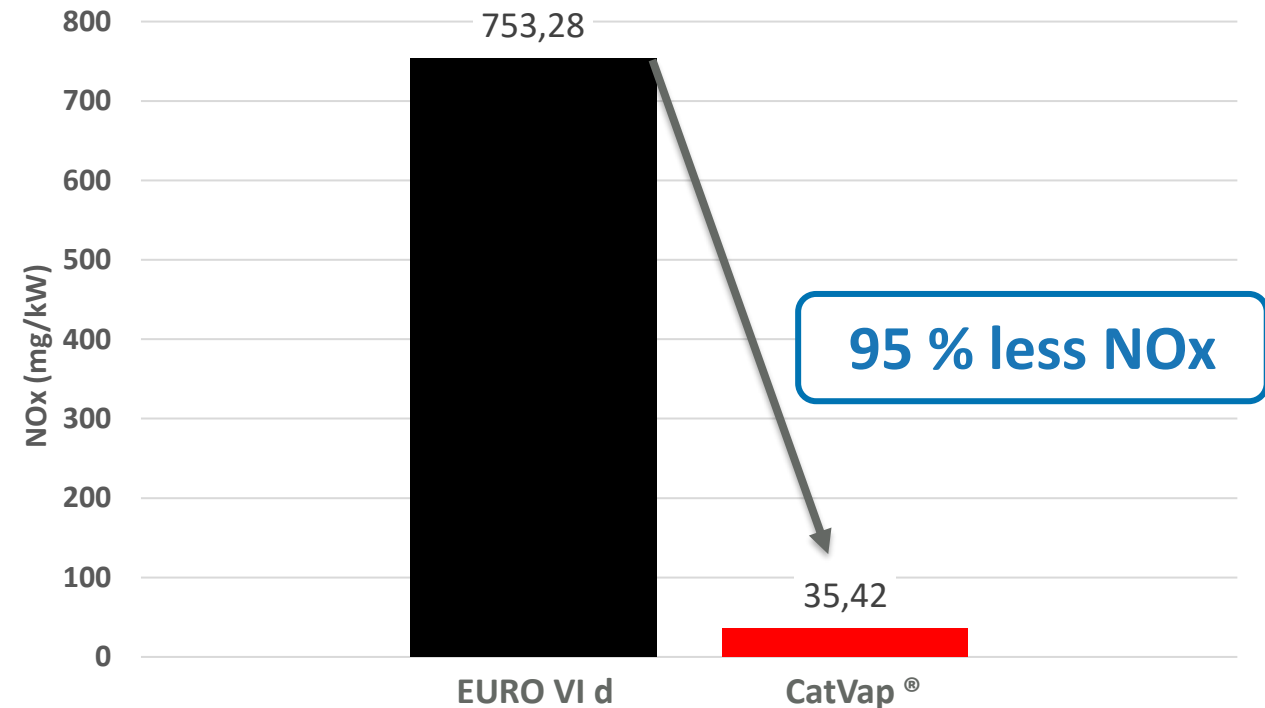

Project kick-off: MEG garbage truck with CatVap[®] to demonstrate ZIV Capability

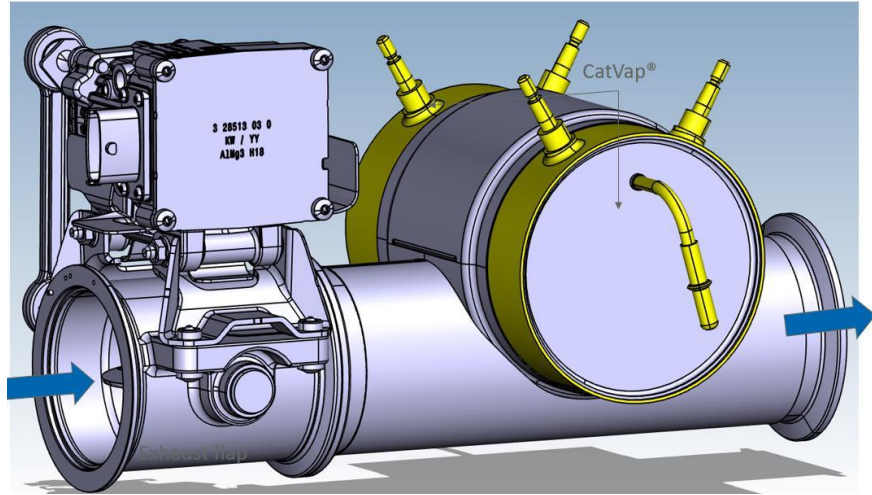

CatVap[®] System



Project Team:
Albonair, HJS,
Remondis, MEG,
transdev,
Fraunhofer ISE



Garbage Truck
Owner: MEG
 $V_H = 10,5 \text{ l}$
 $P = 235 \text{ kW}$
Diesel, EURO VI c

Project Partners



→ Remondis operates 11.000 trucks



→ Transdev operates 47.000 buses



-
- 1 Vision for future Emission Regulation
 - 2 How to achieve Zero Impact Vehicles
 - 3 Real Driving Emissions in Cities
 - 4 Conclusions**

Summary and Conclusion

- urban air quality: NO_x source is mainly traffic, i.e. combustion engines
- “Zero Impact Emissions” (ZIE) and “Zero Impact Vehicles” (ZIV) are defined
- ZIE: the source’s contribution to air pollution is less than 3 %
- To reach ZIV: heating of the exhaust gas is mandatory
- Medium Duty Truck demonstrator: successful demonstration, to achieve ZIV NO_x target of 28,1 mg/kWh
- Albonair has started a field trial in Germany with a garbage truck and a city bus, both equipped with CatVap[®], to demonstrate how ZIV standards can be met
- With e-fuels or biofuels (HVO) it is possible to operate trucks in an environmentally friendly way
- ZIV vehicles driven with e-fuels or biofuels are as environmentally friendly as BEV, H₂ fuel cells or H₂ combustion engine vehicles.

Thank you very much for your attention!



German Engineering for Clean Air

georg.huethwohl@albonair.com